

Monitoraggio remoto di macchinari CNC tramite Elasticsearch

Corso di laurea in informatica per la comunicazione digitale
A.A. 2023/2024

Laureando
Andrea Malloni

Relatore
Prof. **Fausto Marcantoni**

Correlatore
Dott. Ing. **Matteo Malloni**



100.000 €



Cos'è un macchinario CNC?

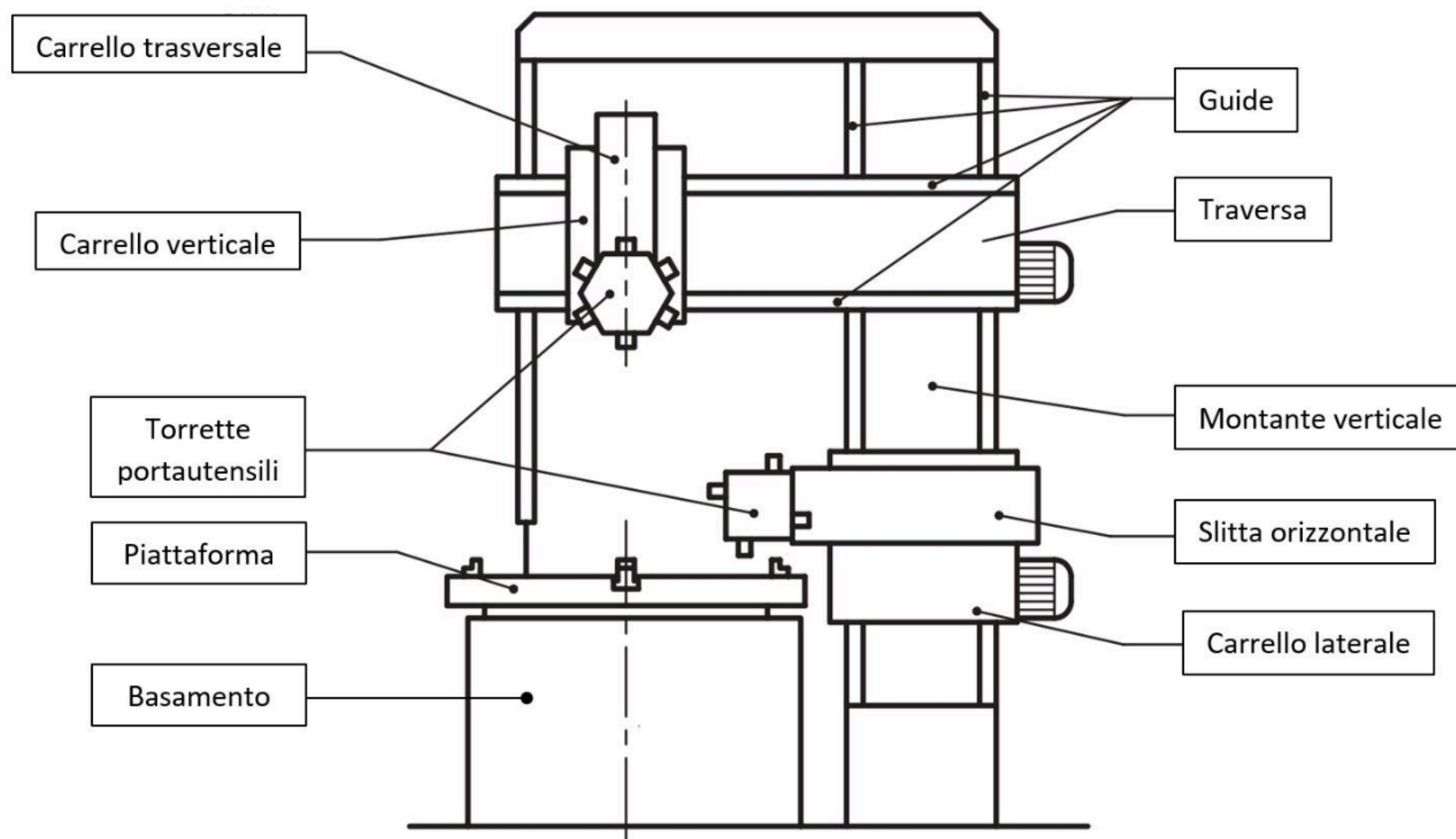

- **Velocità**
- **Durabilità**
- **Precisione**



Come controllo l'operato del macchinario?



Industria 4.0

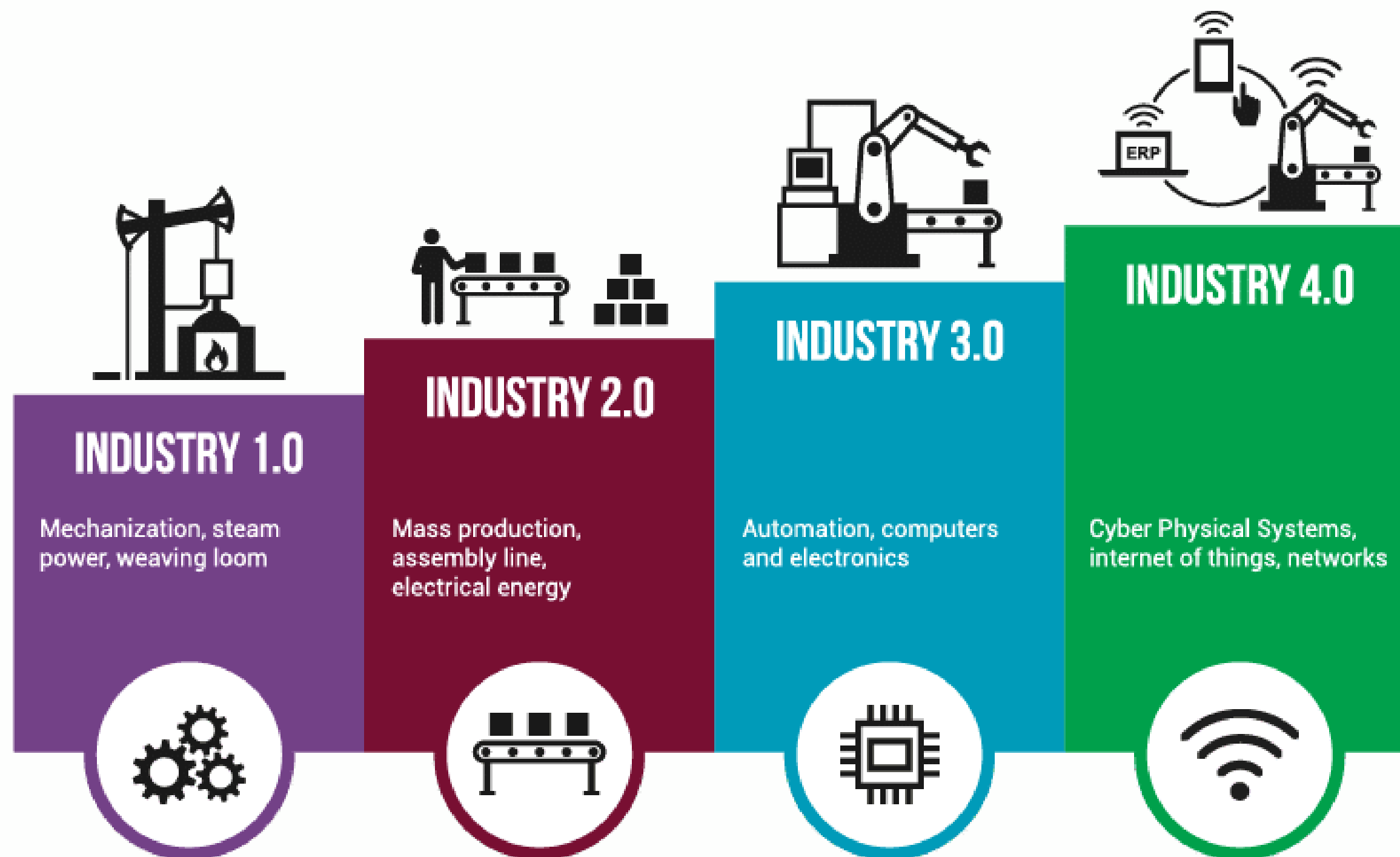

Richieste

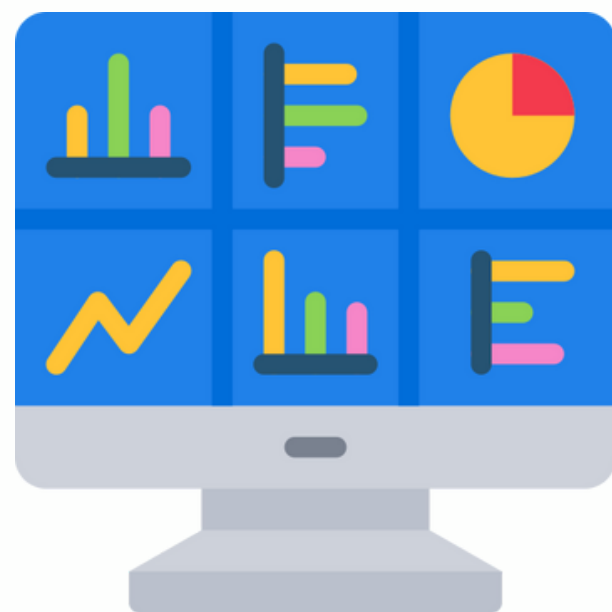

Dashboard



Storico dei log



Infografiche



Specifiche

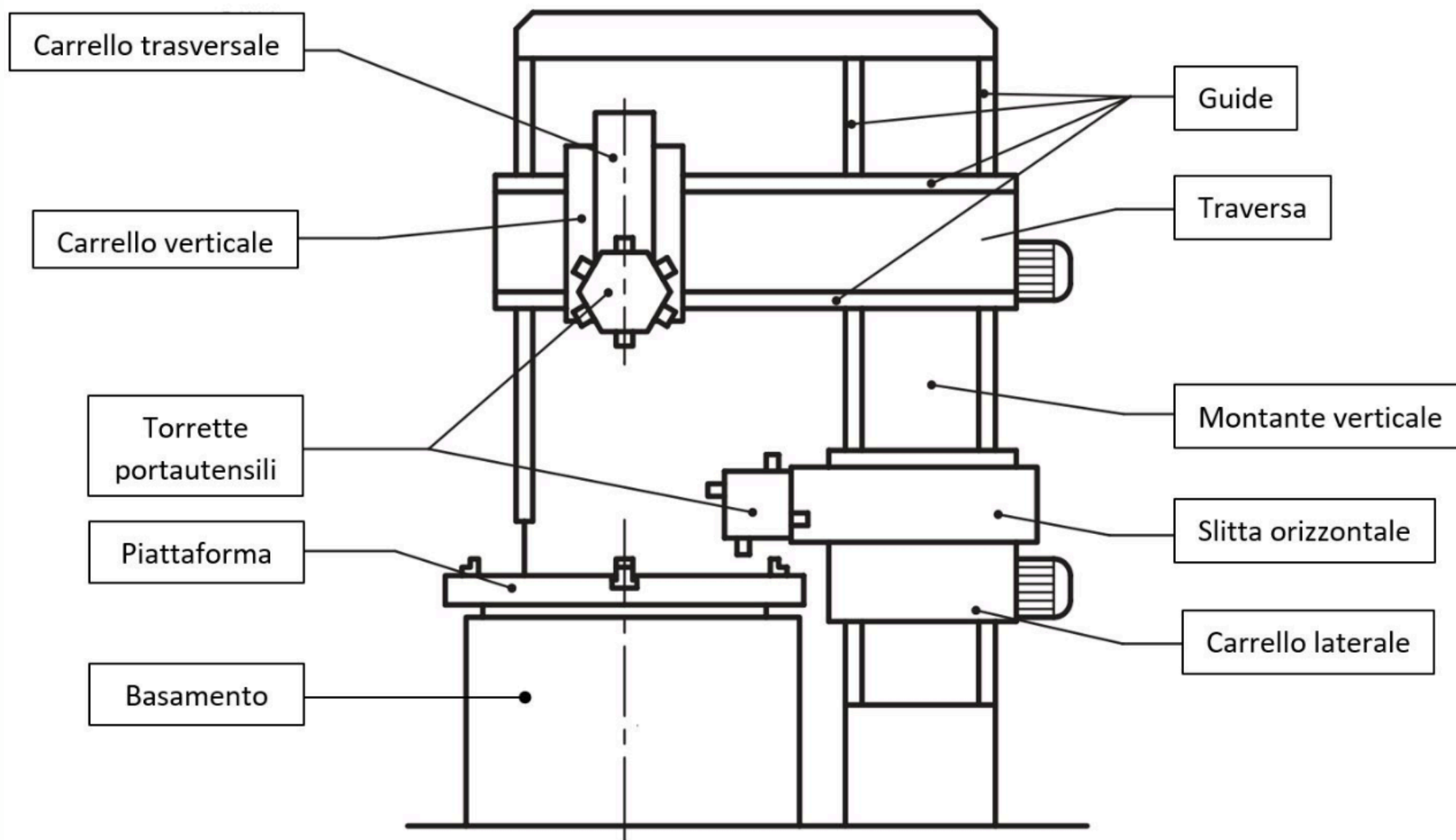

- **Porta di rete**
- **Scrittura su DB**
- **Alta frequenza**



Soluzione: Elastic stack





- **Supporto per dati strutturati, semi-strutturati e non**
- **JSON**
- **Altamente scalabile**
- **Ricerca efficiente**



Logstash



- **Pipeline**
- **Manipolazione dati**
- **Sorgenti multiple**
- **Plugin**





- **Gestione indici Elasticsearch**
- **Dashboards**
- **Gestione utenza**
- **Analisi e insight basati su AI**



Architettura del sistema

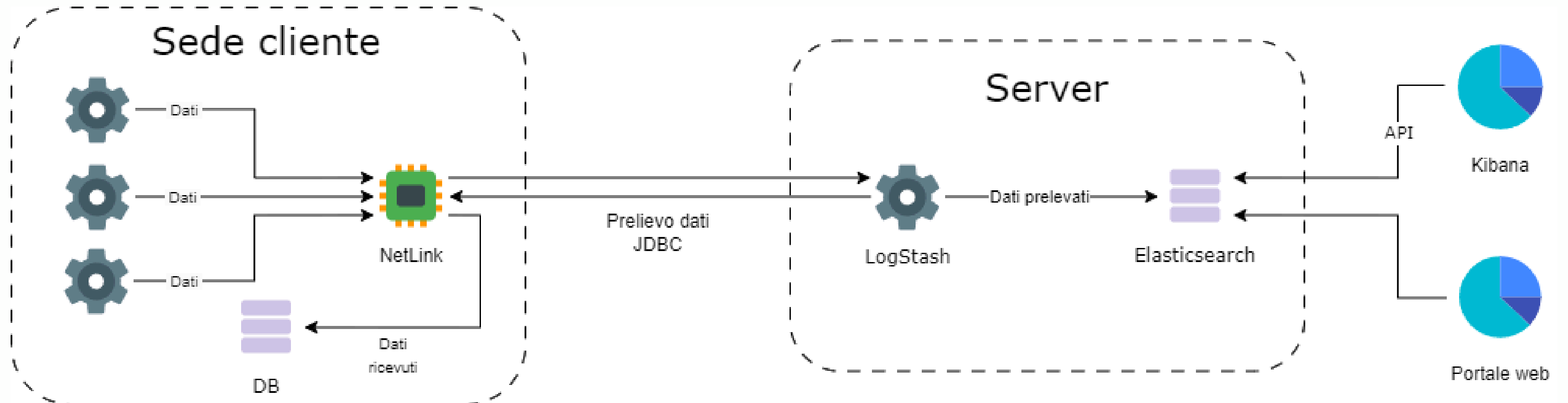

```
mysql> show columns from errori_log;
```

Field	Type	Null	Key	Default	Extra
ler_id	int	NO	PRI	NULL	auto_increment
ler_idcam	int	YES		NULL	
ler_idope	int	YES		NULL	
ler_idtrave	int	YES		NULL	
ler_data	datetime	NO		NULL	
ler_iderrtip	int	YES		NULL	
ler_desc	varchar(255)	NO		NULL	
letto	int	YES		0	

```
8 rows in set (0.00 sec)
```

```
mysql> show columns from cam;
```

Field	Type	Null	Key	Default	Extra
cam_id	int	NO	PRI	NULL	auto_increment
cam_matricola	varchar(21)	NO		NULL	
cam_descrizione	varchar(81)	YES		NULL	
cam_tipo	int	YES		NULL	
cam_consegna	date	YES		NULL	
cam_soft_version	varchar(51)	YES		NULL	
cam_soft_data	date	YES		NULL	
cam_sysope	varchar(81)	YES		NULL	
cam_exec_program	int	YES		NULL	

```
9 rows in set (0.00 sec)
```



Configurazione Logstash

```
input {
  jdbc {
    jdbc_driver_library => "/usr/share/java/mysql-connector-java-8.3.0.jar"
    jdbc_driver_class => "com.mysql.jdbc.Driver"
    jdbc_connection_string => "jdbc:mysql://127.0.0.1:3306/██████████"
    jdbc_user => "root"
    jdbc_password => "elkvm"
    jdbc_paging_enabled => true
    tracking_column => "data"
    use_column_value => true
    tracking_column_type => "timestamp"
    schedule => "*/5 * * * * *"
    statement => "SELECT errori_log.ler_id AS log_id, errori_log.ler_data AS data, errori_log.ler_desc AS
description, errori_log.letto AS checked, cam.cam_matricola AS machine_id, cam.cam_descrizione AS machine_desc
ription FROM errori_log JOIN cam ON errori_log.ler_idcam = cam.cam_id WHERE errori_log.ler_data > :sql_last_valu
e"
  }
}
filter {
  # nessun filtro necessario
}
output {
  elasticsearch {
    hosts => [ "https://localhost:9200" ]
    index => "mysql-content"
    ssl_enabled => true
    cacert => "/usr/share/logstash/certs/http_ca.crt"
    user => "elastic"
    password => "elasticsearch"
  }
}
```



Risultati

elastic
Find apps, content, and more. ^/

New Open Share Alerts Inspect Save

mysql-content
Filter your data using KQL syntax
Refresh

Available fields 8

- @timestamp
- @version
- checked
- data
- description
- log_id
- machine_description
- machine_id

Empty fields 0

Meta fields 3

616 hits
Sort fields

	Document
<input type="checkbox"/>	@timestamp Apr 15, 2024 @ 15:04:15.132 @version 1 checked 0 data Apr 10, 2024 @ 10:10:00.000 description Erro: EMERGENCY STOP log_id 18 machine_description Kombo TAV-R machine_id 00178980 _id rVHb4Y4BLLQounUMsS-J _index mysql-content _score 1
<input type="checkbox"/>	@timestamp Apr 15, 2024 @ 15:04:15.136 @version 1 checked 0 data Apr 10, 2024 @ 10:45:00.000 description Info: Procedura completata log_id 50 machine_description Kombo 31-20 T machine_id 00178984 _id r1Hb4Y4BLLQounUMsS-J _index mysql-content _score 1
<input type="checkbox"/>	@timestamp Apr 15, 2024 @ 15:04:15.134 @version 1 checked 0 data Apr 13, 2024 @ 10:40:00.000 description Info: Procedura completata log_id 37 machine_description Kombo 31-21 T machine_id 00178983 _id u1Hb4Y4BLLQounUMsS-N _index mysql-content _score 1
<input type="checkbox"/>	@timestamp Apr 15, 2024 @ 15:04:15.132 @version 1 checked 0 data Apr 10, 2024 @ 10:55:00.000 description Warn: Temperature alte log_id 20 machine_description Kombo S D machine_id 00178981 _id u1Hb4Y4BLLQounUMsS-V _index mysql-content _score 1
<input type="checkbox"/>	@timestamp Apr 15, 2024 @ 15:04:15.132 @version 1 checked 0 data Apr 10, 2024 @ 10:34:00.000 description Info: Attivazione software log_id 21 machine_description Kombo 31-21 T machine_id 00178982 _id vFHb4Y4BLLQounUMsS-V _index mysql-content _score 1
<input type="checkbox"/>	@timestamp Apr 15, 2024 @ 15:04:15.132 @version 1 checked 0 data Apr 11, 2024 @ 10:34:00.000 description Info: Attivazione software log_id 22 machine_description Kombo 31-21 T machine_id 00178982 _id vVHb4Y4BLLQounUMsS-V _index mysql-content _score 1
<input type="checkbox"/>	@timestamp Apr 15, 2024 @ 15:04:15.132 @version 1 checked 0 data Apr 12, 2024 @ 10:34:00.000 description Info: Attivazione software log_id 23 machine_description Kombo 31-21 T machine_id 00178982 _id v1Hb4Y4BLLQounUMsS-V _index mysql-content _score 1
<input type="checkbox"/>	@timestamp Apr 15, 2024 @ 15:04:15.133 @version 1 checked 0 data Apr 13, 2024 @ 10:34:00.000 description Info: Attivazione software log_id 24 machine_description Kombo 31-21 T machine_id 00178982 _id v1Hb4Y4BLLQounUMsS-V _index mysql-content _score 1

Rows per page: 100
< 1 2 3 4 5 >



HTML



CSS



JS



AdminLTE



Dashboard e dettagli

CNCViewer Home Search Statistics About Contact Andrea 

00178983

Status: Healthy

Log details

00178982

Status: Error

Log details

00178984

Status: Healthy

Log details

00178980

Status: Error

Log details

00178985

Status: Healthy

Log details

00178975

Status: Error

Log details

00178986

Status: Healthy

Log details

00178976

Status: Error

Log details

Log details ✕

Show Search:

entries

Log ID	Machine ID	Description	Version	Date	Log Info	Checked
33	00178983	Kombo 31-21T	1	2024-04-13 10:34:00	Info: Attivazione software	false
33	00178983	Kombo 31-21T	1	2024-04-13 10:34:00	Info: Attivazione software	false
34	00178983	Kombo 31-21T	1	2024-04-10 10:40:00	Warn: Temperature alte	false
34	00178983	Kombo 31-21T	1	2024-04-10 10:40:00	Warn: Temperature alte	false
34	00178983	Kombo 31-21T	1	2024-04-10 10:40:00	Warn: Temperature alte	false

Showing 31 to 35 of 96 entries

[Previous](#)
1 ... 6 **7** 8 ... 20
[Next](#)

[Close](#)



Ricerca

Search

Log Type: Machine ID: From: Until:

Machine Description:

Log ID	Machine ID	Description	Version	Date	Log Info	Checked
69	00178986	Kombo 31-22T	1	2024-04-13 10:34:00	Info: Attivazione software	false
69	00178986	Kombo 31-22T	1	2024-04-13 10:34:00	Info: Attivazione software	false
70	00178986	Kombo 31-22T	1	2024-04-10 10:40:00	Warn: Temperature alte	false
70	00178986	Kombo 31-22T	1	2024-04-10 10:40:00	Warn: Temperature alte	false
70	00178986	Kombo 31-22T	1	2024-04-10 10:40:00	Warn: Temperature alte	false

Showing 551 to 555 of 616 entries



Search

From

10/04/2024

Until

13/04/2024

Search

Percentage of logs per type



Logs per day

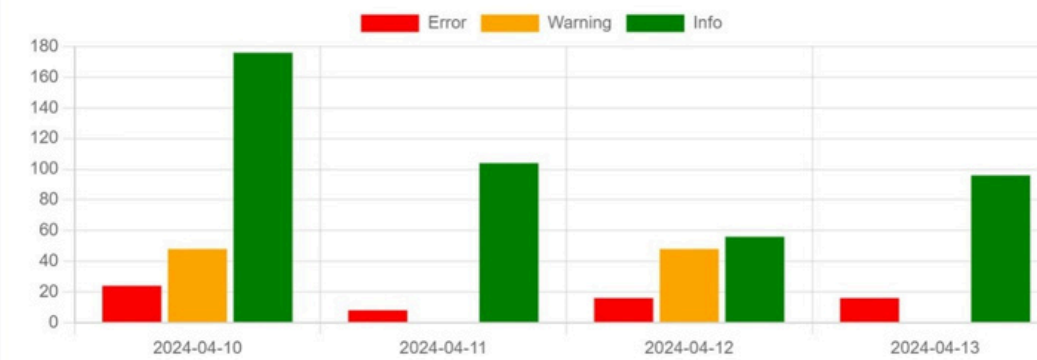

Percentage of errors per machine model

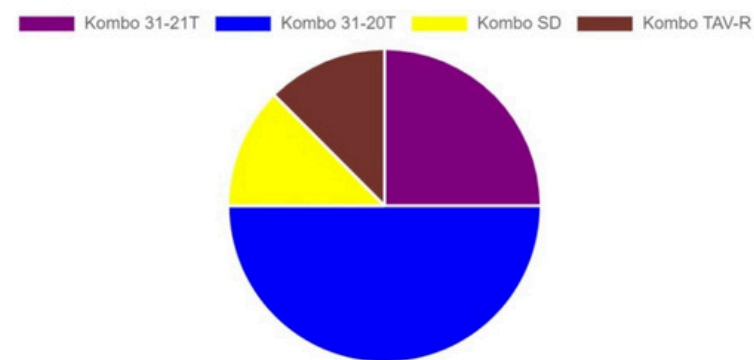

Percentage of warnings per machine model

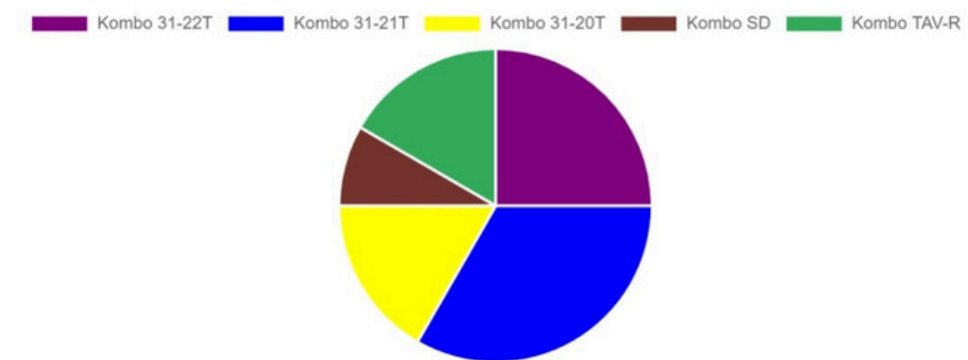

Ottimizzazioni

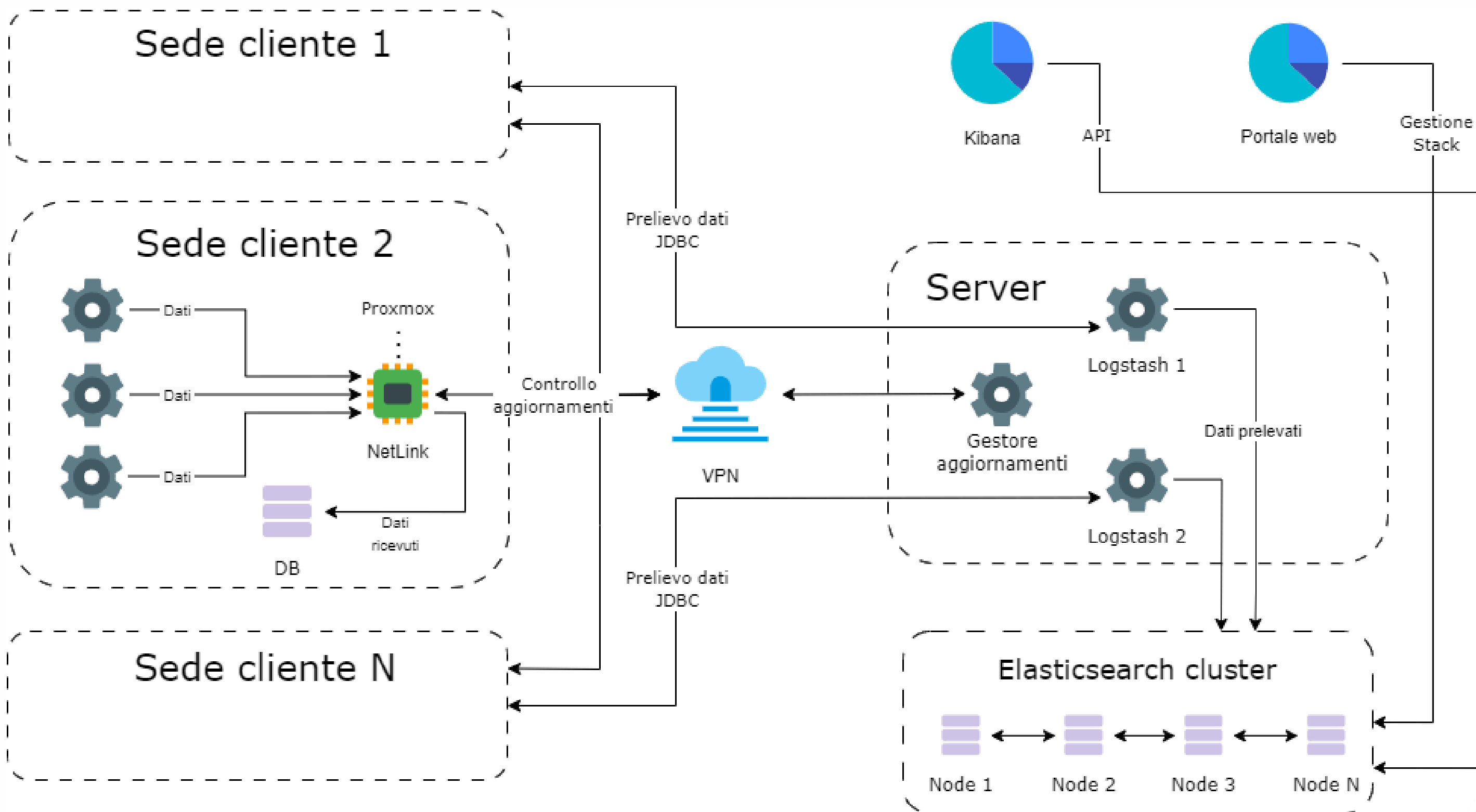

Elasticsearch sharding

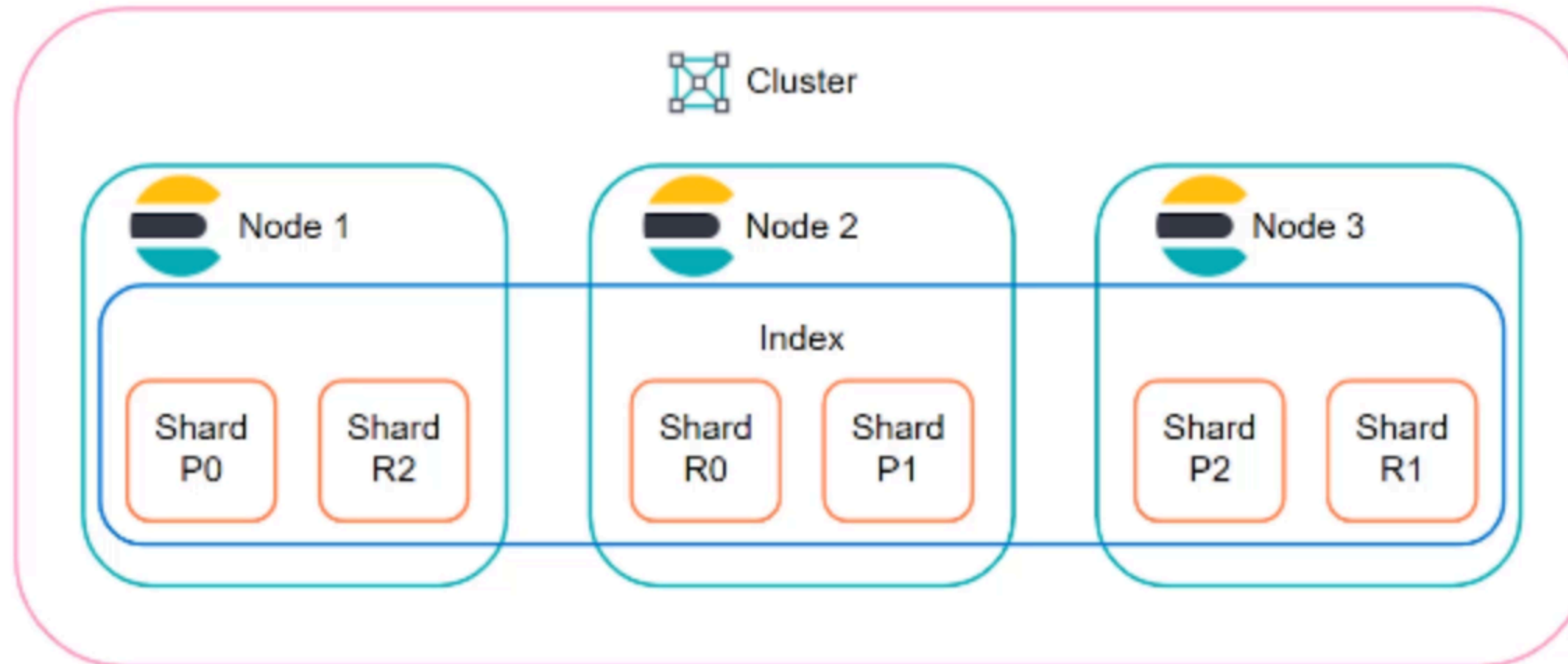

Come gestire multipli utenti?



- **Separazione degli indici**
- **Agenti Logstash personali**
- **Ruoli ed autorizzazioni**



Autoprovisioning



OPENVPN

Sicurezza

PROXMOX

Aggiornamento



Grazie per l'attenzione

